

# Vertigo Series

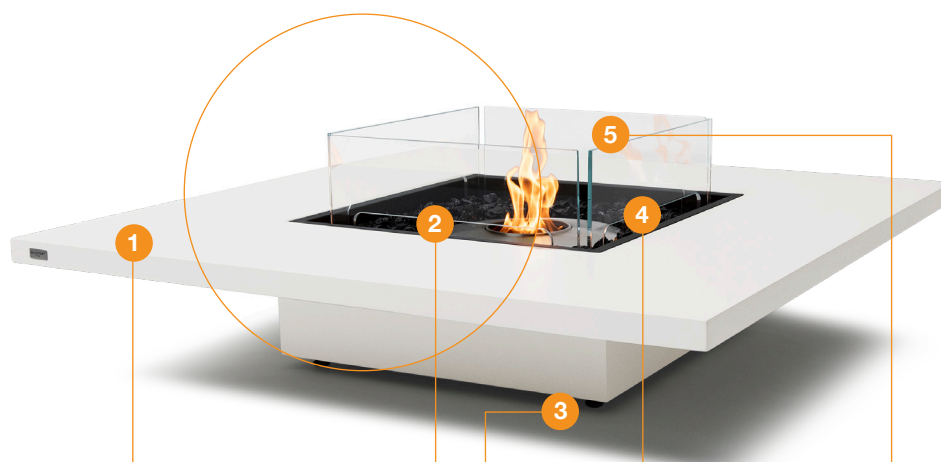

# Vertigo Series Design features



## 1. Fluid™ Concrete Finish

Incredibly strong yet relatively lightweight, EcoSmart's concrete products incorporate revolutionary Fluid Concrete Technology. Fluid features a stain and impact-resistant barrier that protects the concrete from environmental weathering – even under extreme conditions and long UV exposure.

## Surround Colours/Finish

Available in three Fluid Concrete colours: Natural, Graphite and Bone.

## 2. Burner Colours

Available with a Stainless Steel or Black Burner.

## 3. Articulating Feet

Our Fire Pits and Tables feature 360° height-adjustable articulating feet, so you can achieve a perfectly level and stable model before operating the fireplace.

## Quick & Easy Installation

With no installation or building works required, simply unpack, put into position, and off you go.

## 4. Decorative Media

Models come with black glass charcoal to add the finishing touch. They do not emit any toxic fumes, smoke, or ash and are extremely easy to maintain and clean.

## Environmentally-Friendly

Bioethanol fireplaces use an environmentally-friendly, renewable energy source that burns clean and delivers warming heat. You and your guests will enjoy the ambiance and tranquility of a real fire, without the hassles of burning real wood - no more embers, ash, and soot to clean up.

## 5. Glass Fire Screen

Designed to accommodate two different glass fire screens: Raised Round or Recessed Square.

## Ground Fixing Brackets

Models come with fixing brackets for permanently locating into a fixed position.

## Global Compliance

These models comply with existing standards in the USA, Europe, UK and Australia. O-TL listed to UL 1370, EN 16647 BSI Certified and ACCC Safety Mandate compliant.



Natural



Graphite



Bone

Disclaimer. All product specifications and data are subject to change without notice and believed to be correct at the time of publication. MAD Design Group (MDG), its affiliates, agents, and employees, and all persons acting on its or their behalf (collectively, "MAD Design Group"), disclaim any and all liability for any errors, inaccuracies or incompleteness contained herein or in any other disclosure relating to any product. MDG disclaims any and all liability arising out of the use or application of any product described herein or of any information provided herein to the maximum extent permitted by law. The product specifications do not expand or otherwise modify MDG's terms and conditions of purchase, including but not limited to the warranty expressed therein, which apply to these products. No license, express or implied, by estoppel or otherwise, to any intellectual property rights is granted by this document or by any conduct of MDG. Customers using or selling MDG products not expressly indicated for use in such applications do so entirely at their own risk and agree to fully indemnify MDG for any damages arising or resulting from such use or sale. Please contact authorised personnel from MDG to obtain written terms and conditions regarding products designed for such applications. Images are indicative only.

# Vertigo Series Accessories



## Included accessories



### Decorative Glass Charcoal

Our Glass Charcoal is made from high-quality tempered glass.



### Glass Fire Screen

Model includes a recessed square glass fire screen, to stabilise the flame in windy conditions.



### Jerry Can with Safety Spout and e-NRG bottle adaptor

Jerry Can allows safe storing/decanting of e-NRG ethanol. e-NRG adaptor connects the Safety Spout to an e-NRG bottle.



### Lighting Rod & Lighter

The Lighting Rod is designed to safely adjust the slider position on the burner. It is also used for the ignition procedure.



### AB8 Efficiency Ring

Placed over the internal burner vent, it serves to increase the efficiency of the burner as well as further stabilise the flame.

## Optional accessories



### Glass Fire Screen

This model is compatible with a raised round fire screen depending on the look you prefer.

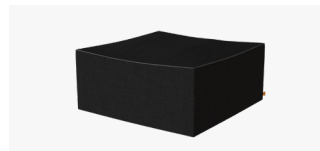

### All Seasons Cover

Take care and protect your investment with our stain and water resistant custom outdoor cover.

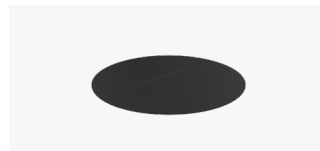

### Silicone Burner Cover

Black silicone burner covers protect burners from the elements when not in use.

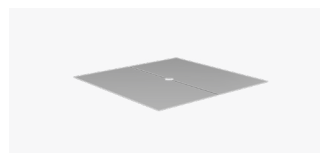

### Glass Cover Plate

Enables fire pit tables to easily be transformed into a usable coffee table surface.





# Vertigo 40 Specifications

Vertigo 40 is the smallest of the Vertigo Series. Makes a statement in both indoor and outdoor settings; a unique, low-set square coffee table for all seasons.

## Ventilation and Efficiency\*

Model Dimensions L x W x H mm/in	Compatible Burner	Fuel Capacity	Heats on Average (Indoors)	Thermal Output Net (MAX per burner)	Approx. Burn Time	Minimum Room Size
1000 x 1000 x 250 39.4 x 39.4 x 9.8	AB8	8 L [2.1 Gals]	Over 60 m <sup>2</sup> [645 ft <sup>2</sup> ]	21.56 MJ/h 20,433 BTU/h, 5.99 kW	7 - 9 hours	116 m <sup>3</sup> [4,096 ft <sup>3</sup> ]
			Over 30 m <sup>2</sup> [322.9 ft <sup>2</sup> ]	13.9 MJ/h 12,860 BTU/h, 3.77 kW	9 - 11 hours	

With Efficiency Ring\*\* (EN Compliant)

Application <sup>1</sup>	Indoor & Outdoor	
Surround Colours	 Natural ESF.O.VTG.40.NA	 Graphite ESF.O.VTG.40.GH
	 Bone ESF.O.VTG.40.BO	
Burner Colours	 Stainless Steel	 Black
Materials	Fluid Concrete Surround, Grade 304 Stainless Steel Burner, with optional Black Ceramic Coating	
Approx. Weight	69.3kg [152.5lbs] Weight includes burner, glass charcoal & glass fire screen.	
Fuel Type	e-NRG Bioethanol / <a href="http://e-NRG.com">e-NRG.com</a>	

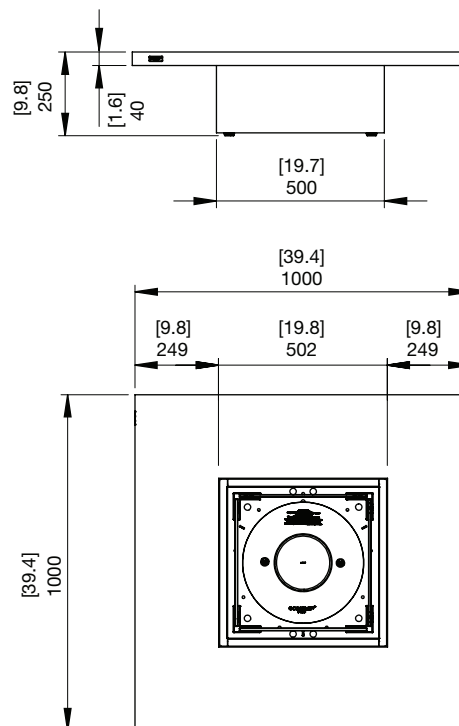

Line drawings show concrete models without a Fire Screen. Refer to the Fire Screen model specifications for dimensions.

\*These values are indicative only and may vary depending on the model purchased, installation, and the seasonal resource used to manufacture e-NRG.

<sup>1</sup>For Indoor Use, additional parts are required. Your chosen application is the ONLY application the model can be used in due to modified configuration of the model. Please advise your Sales Representative at time of purchase so that the product can be configured accordingly.

This model complies with existing standards in the USA, Europe, UK and Australia. O-TL listed to UL 1370, EN 16647 BSI Certified and ACCC Safety Mandate compliant. \*\*To comply with EN 16647 the Indoor Safety Tray & included AB8 Burner Efficiency Ring must be installed before operating indoors.

## FOR MORE INFORMATION PLEASE REFERENCE THE CLEARANCE & INSTALLATION MANUAL

Disclaimer. All product specifications and data are subject to change without notice and believed to be correct at the time of publication. MAD Design Group (MDG), its affiliates, agents, and employees, and all persons acting on its or their behalf (collectively, "MAD Design Group"), disclaim any and all liability for any errors, inaccuracies or incompleteness contained herein or in any other disclosure relating to any product. MDG disclaims any and all liability arising out of the use or application of any product described herein or of any information provided herein to the maximum extent permitted by law. The product specifications do not expand or otherwise modify MDG's terms and conditions of purchase, including but not limited to the warranty expressed therein, which apply to these products. No license, express or implied, by estoppel or otherwise, to any intellectual property rights is granted by this document or by any conduct of MDG. Customers using or selling MDG products not expressly indicated for use in such applications do so entirely at their own risk and agree to fully indemnify MDG for any damages arising or resulting from such use or sale. Please contact authorised personnel from MDG to obtain written terms and conditions regarding products designed for such applications. Images are indicative only.





# Vertigo 50 Specifications

Vertigo 50 is the largest of the Vertigo Series. Its low-set, square-shaped design has ample proportions for setting down food and drinks.

## Ventilation and Efficiency\*

Model Dimensions L x W x H mm/in	Compatible Burner	Fuel Capacity	Heats on Average (Indoors)	Thermal Output Net (MAX per burner)	Approx. Burn Time	Minimum Room Size
1270 x 1270 x 250 50 x 50 x 9.8	AB8	8 L [2.1 Gals]	Over 60 m <sup>2</sup> [645 ft <sup>2</sup> ]	21.56 MJ/h 20,433 BTU/h, 5.99 kW	7 - 9 hours	116 m <sup>3</sup> [4,096 ft <sup>3</sup> ]
			Over 30 m <sup>2</sup> [322.9 ft <sup>2</sup> ]	13.9 MJ/h 12,860 BTU/h, 3.77 kW	9 - 11 hours	

With Efficiency Ring\*\* (EN Compliant)

Application <sup>1</sup>	Indoor & Outdoor	
Surround Colours	 Natural ESF.O.VTG.50.NA	 Graphite ESF.O.VTG.50.GH
	 Bone ESF.O.VTG.50.BO	
Burner Colours	 Stainless Steel	 Black
Materials	Fluid Concrete Surround, Grade 304 Stainless Steel Burner, with optional Black Ceramic Coating	
Approx. Weight	94.8kg [208.6lbs] Weight includes burner, glass charcoal & glass fire screen.	
Fuel Type	e-NRG Bioethanol / <a href="http://e-NRG.com">e-NRG.com</a>	

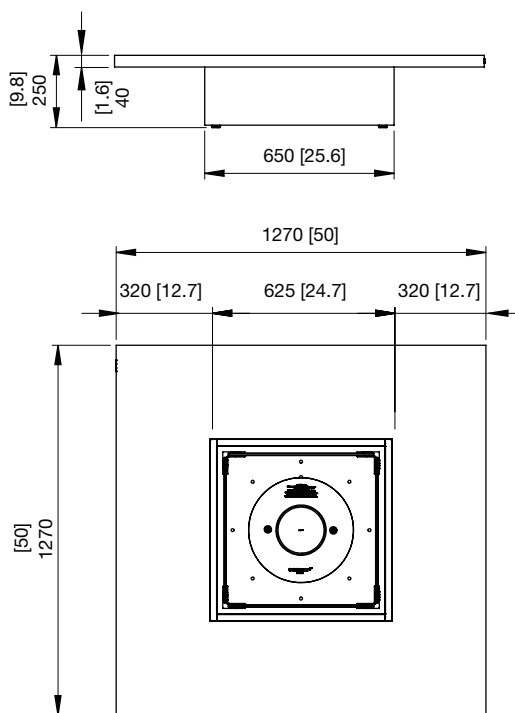

Line drawings show concrete models without a Fire Screen. Refer to the Fire Screen model specifications for dimensions.

\*These values are indicative only and may vary depending on the model purchased, installation, and the seasonal resource used to manufacture e-NRG.

<sup>1</sup>For Indoor Use, additional parts are required. Your chosen application is the ONLY application the model can be used in due to modified configuration of the model. Please advise your Sales Representative at time of purchase so that the product can be configured accordingly.

This model complies with existing standards in the USA, Europe, UK and Australia. O-TL listed to UL 1370, EN 16647 BSI Certified and ACCC Safety Mandate compliant. \*\*To comply with EN 16647 the Indoor Safety Tray & included AB8 Burner Efficiency Ring must be installed before operating indoors.

## FOR MORE INFORMATION PLEASE REFERENCE THE CLEARANCE & INSTALLATION MANUAL

Disclaimer. All product specifications and data are subject to change without notice and believed to be correct at the time of publication. MAD Design Group (MDG), its affiliates, agents, and employees, and all persons acting on its or their behalf (collectively, "MAD Design Group"), disclaim any and all liability for any errors, inaccuracies or incompleteness contained herein or in any other disclosure relating to any product. MDG disclaims any and all liability arising out of the use or application of any product described herein or of any information provided herein to the maximum extent permitted by law. The product specifications do not expand or otherwise modify MDG's terms and conditions of purchase, including but not limited to the warranty expressed therein, which apply to these products. No license, express or implied, by estoppel or otherwise, to any intellectual property rights is granted by this document or by any conduct of MDG. Customers using or selling MDG products not expressly indicated for use in such applications do so entirely at their own risk and agree to fully indemnify MDG for any damages arising or resulting from such use or sale. Please contact authorised personnel from MDG to obtain written terms and conditions regarding products designed for such applications. Images are indicative only.